

8900 EMF (NO DETECTOR)



Each (HO) hold open unit contains a door closer and track assembly with hold open electromagnet.

The unit can be connected directly to a fire control panel.

1. Read entire instruction sheet prior to installation and refer to NFPA 72E. Standards may be obtained from THE NATIONAL FIRE PROTECTION ASSOCIATION, Batterymarch Park, Quincy, MA., 02269.
2. Reference unit carton for mounting style and voltage.
3. Prepare door and frame for fasteners using the appropriate template. Mark, drill and tap holes as indicated. If surface wiring is used, omit 7/8" hole for wire access.

4 Install closer to door.

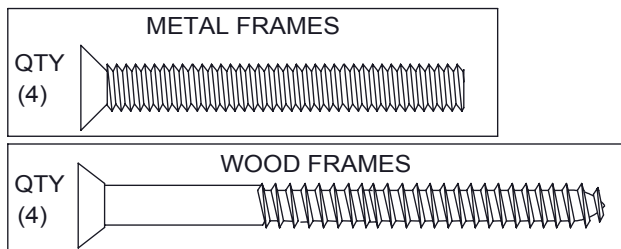

8900T AND 8900DE

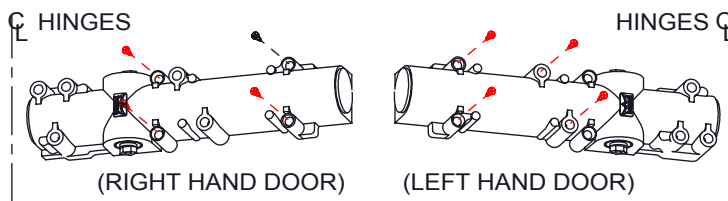

8900PT

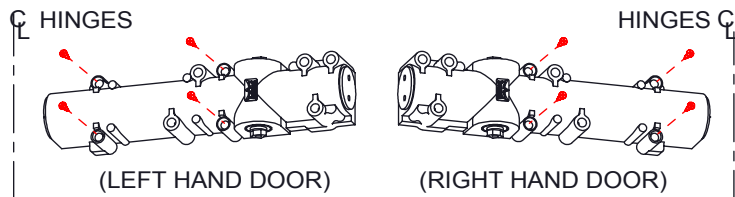

5 Remove (1) wire access plug according to the installation type. Any access hole can be used for surface wiring installations.

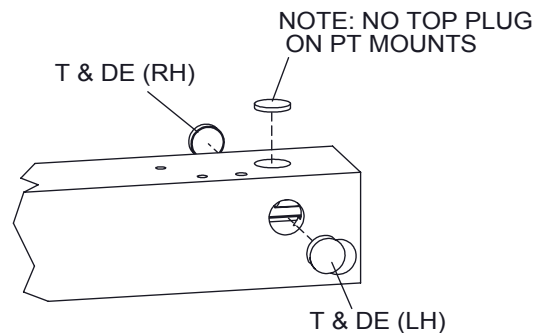

NOTE:
Three access wire holes on optional surface wired units only.

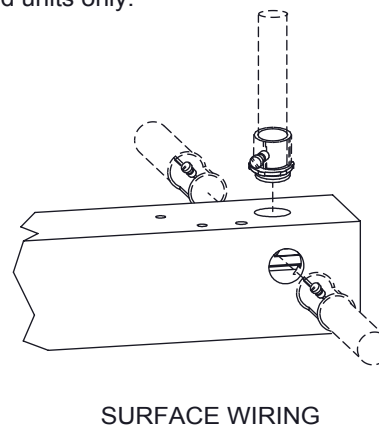

6 Install track to frame.

8900T AND 8900DE

Install with wire access plugs toward latch edge of door using (2) 1/4-20 x 2" metal or (2) No. 14 x 2-3/4" wood screws. Route wires from frame through appropriate wire access hole in track, being careful not to pinch wires during installation.

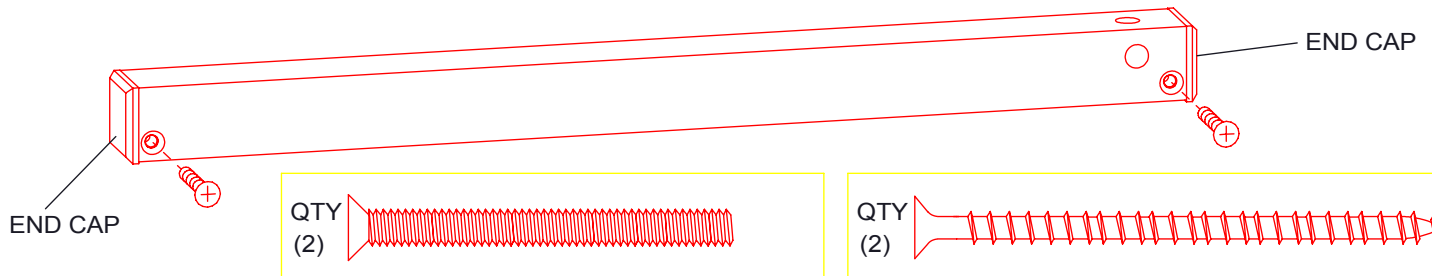

Install PT track to soffit with wire access plugs toward hinge. Install with (1) 1/4-20 x 1-1/4" combo screw and (1) 1/4-20 x 2" metal or (1) No.14 x 2-3/4" wood screw as shown. Route wires from frame through appropriate wire access hole in track, being careful not to pinch wires during installation. (DO NOT INSTALL END CAP ON HINGE SIDE IN THIS STEP)

8900PT

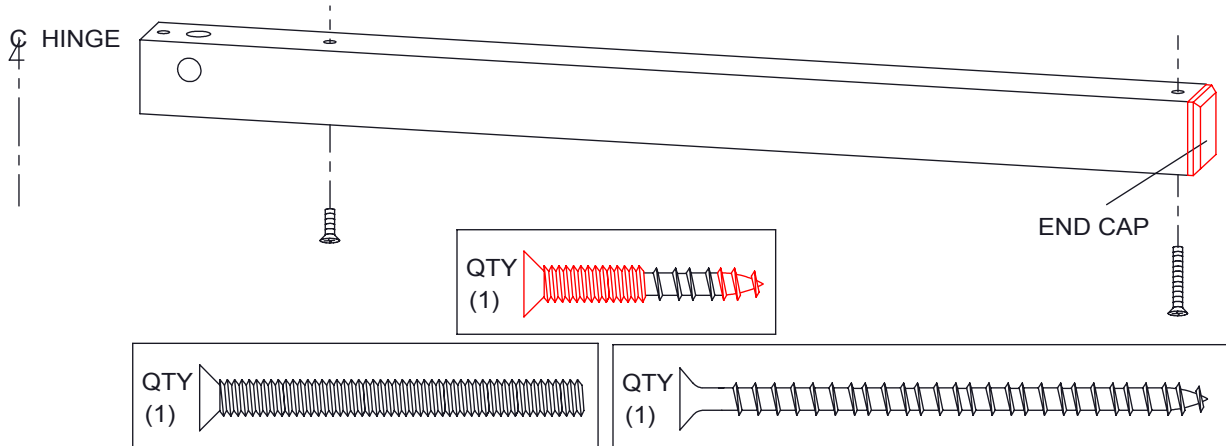

7 Slide wiring connection cover to allow access to wire connections.

Determine power supply and unit voltage type: 24VAC, 24VDC. CAUTION!!! DO NOT CONNECT 120VAC TO A 24 VOLT UNIT TYPE!!! Connect power supply wires to terminal block as shown (Terminal Block can be removed for easier wiring). Be sure to use ground screw for power supply ground wire when supplying 120VAC. Slide wiring connection cover over wire connections.

CAUTION: Improper voltage to unit will result in damage to unit and void warranty.

NOTE: All wiring must comply with national, state and local electrical codes.

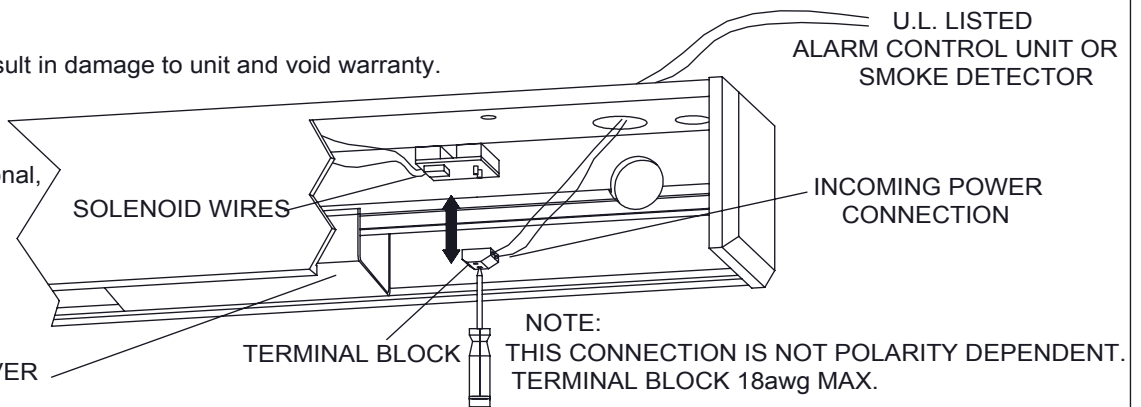

8 8900PT ONLY Insert cover into track, align end cap in end of track.

Install remaining screw as shown using 1/4-20 x 2" metal or No. 14 x 2-3/4" wood screw.

U.L. LISTED ALARM CONTROL UNIT OR SMOKE DETECTOR

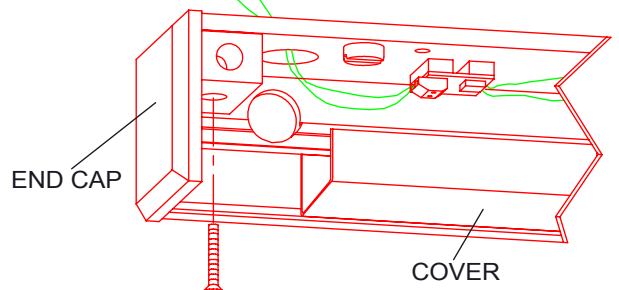
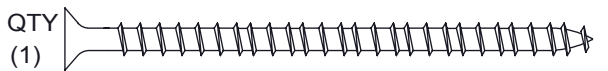
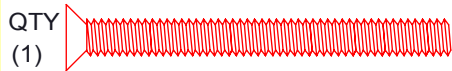

9 Attach main arm to door closer.

8900T

With door in closed position, rotate spindle 45° with wrench. Place arm on spindle parallel to door and secure arm with pinion screw and washer.

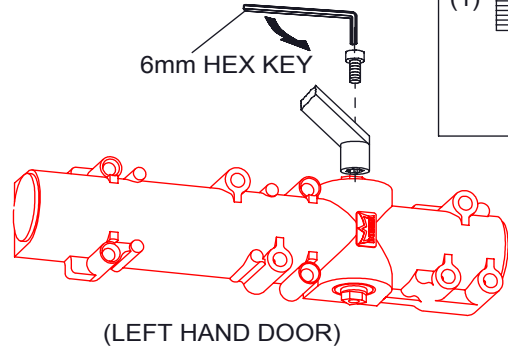
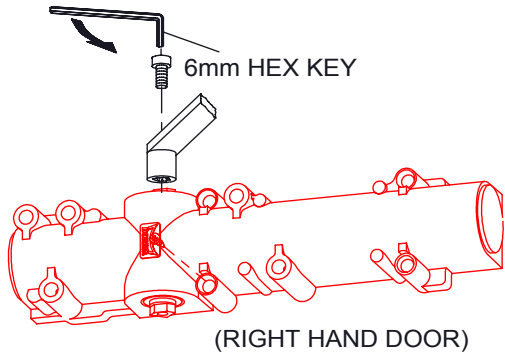
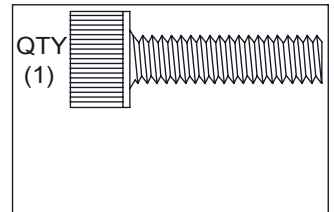

8900DE

With door in closed position, rotate spindle 45° with wrench. Place arm on spindle parallel to door and secure arm with pinion screw and washer.

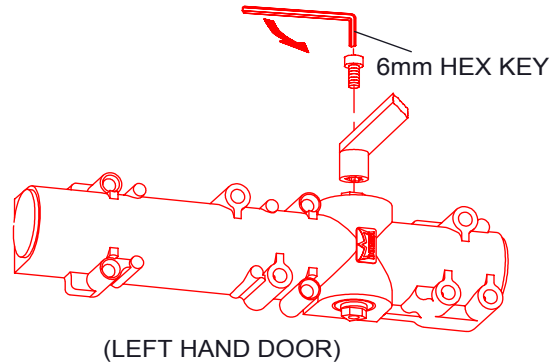
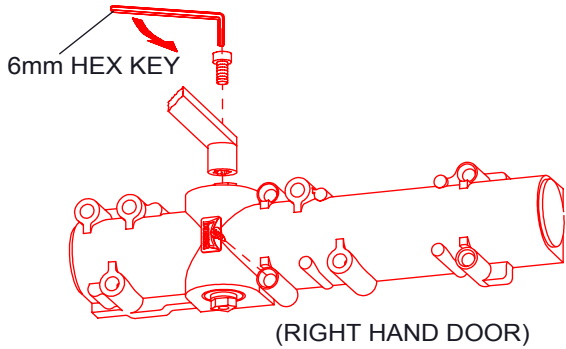

8900PT

With door in closed position, rotate spindle 45° with wrench. Place arm on spindle parallel to door and secure arm with pinion screw and washer.

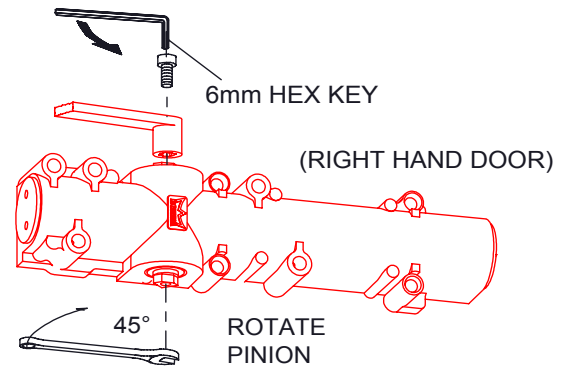
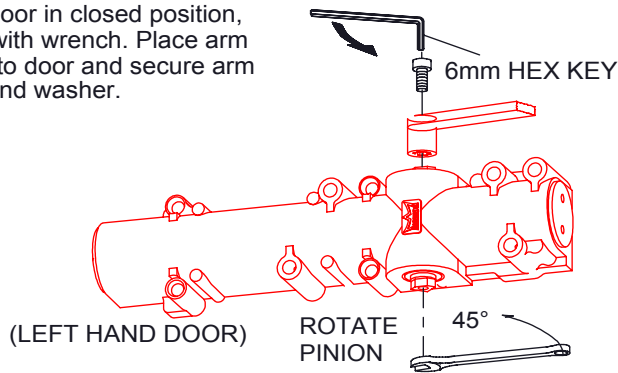

10 Attach arm to slide shoe. Use 3/16 inch hex head wrench.

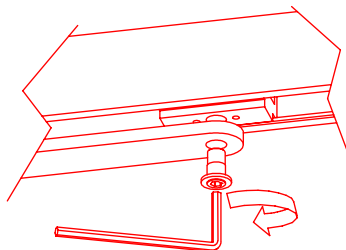

11 Adjust spring tension, if required, using a 1/4" wrench.

NOTE: 8916 supplied with size 3 spring setting.
8956 supplied with size 6 setting.

CRITICAL

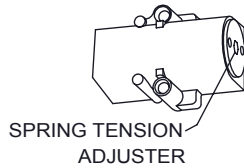

Adjust according to chart.

CLOSER TYPE	DOOR WIDTH	FULL TURNS OF SPRING ADJUSTER	SPRING SIZE
	INTERIOR		
8916	2'-6"	0	4
	3'-0"	+8	5
	3'-6"	+16	6
8956	3'-6"	0	6
	4'-0"	+6	6+

NOTE: DO NOT ADJUST SPRING LOWER THAN SIZE 3

ULC LABELED UNITS ONLY
ADJUST SPRING TENSION ACCORDING TO THE FOLLOWING CHART.

CLOSER TYPE	MAX. DOOR WEIGHT	SPRING SIZE	FULL TURNS OF SPRING ADJUSTING NUT
8916	125	4	0
	150	5	+8
	200	6	+16
8956	200	6	0
	250	6+	+6

NOTE: DO NOT ADJUST SPRING LOWER THAN SIZE 3

12 Adjust sweep, latch and backcheck valves.

CAUTION: DO NOT REMOVE VALVES.
BACKCHECK RANGE

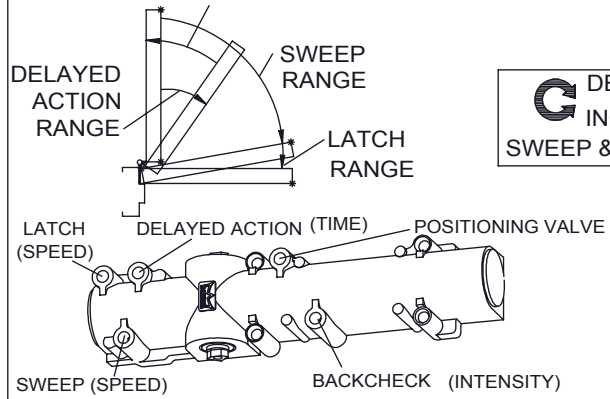

13 Hold open position is preset at approximately 90°.

Loosen set screws using 3/32 inch hex wrench slide hold open device for desired position.
Retighten set screws securely.

HOLD OPEN DEVICE

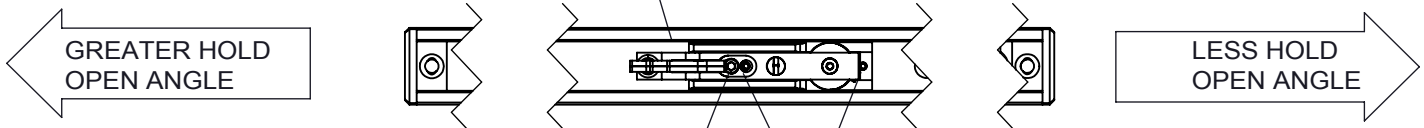

HOLD OPEN FORCE ADJUSTMENT - 5/32 HEX
CLOCKWISE = STRONGER

HOLD OPEN SET SCREWS - 3/32 HEX

NOTE: POWER MUST BE SUPPLIED TO RESET POSITION.

14 Place tab in cover slot opposite main arm.
Place cover over closer and fasten securely with screws provided.

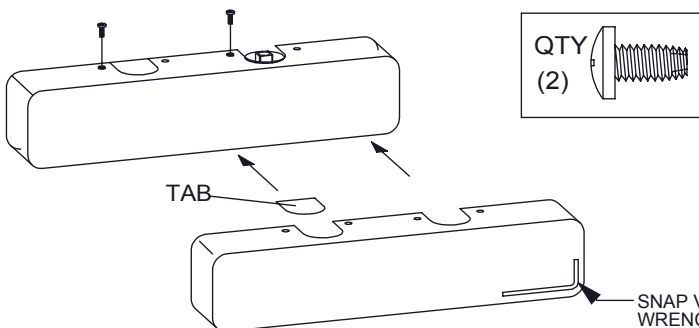

NOTE: LEFT HAND INSTALLATION SHOWN. RIGHT HAND IS A MIRROR IMAGE (T & DE)

- 15 Final installation and test.
1. After installation is completed, recheck all connections. Apply power to units.
 2. Open door so slide block engages with hold open assembly.
 3. Advise fire officials prior to testing.
 4. Activate system into alarm so the electromagnet releases and the doors closes.
 5. If the closer is used in conjunction with a detected unit, trip the test switch of the main closer detector as explained in the test procedure for that unit. After a short time delay, the hold open electromagnet of both units will release and the doors will close. Resetting the test switch will allow the units to return to standby.

17

IMPORTANT: THE UNIT MUST BE TESTED AFTER THE INSTALLATION, BY THE END USER, TO ASSURE THAT THE DOOR CLOSER UNITS FUNCTION PROPERLY WHEN THE ALARM SYSTEM IS ACTIVATED. THE ENTIRE SYSTEM MUST ALSO BE TESTED PERIODICALLY AFTER THE INITIAL INSTALLATION TEST, IN CONJUNCTION WITH THE TESTING OF THE FIRE ALARM SYSTEM. THE END USER IS ALSO RESPONSIBLE FOR THE ADJUSTMENTS AND MAINTENANCE TO RETAIN THE SYSTEM IN WORKING ORDER.

18 OPERATION

NORMAL- The closer unit's solenoid will be energized across a normally closed alarm contact from 24VDC, 24VAC or 120VAC power supply based on unit voltage.

FIRE ALARM- When the alarm sounds, the alarm contact will open and interrupt current to the solenoid which releases the hold open allowing the door to close and latch.

ELECTRICAL SPECIFICATION

Voltage input- 24VDC +10% -15%
24VAC +10% -15%

Maximum input current- 24VDC 166mA
24VAC 166mA

16

An auxiliary door stop (by others) must be installed to limit the maximum degree of door swing. Failure to do so may result in damage to the unit.

OPTIONAL:
BYPASS SWITCH

Slide wiring connection cover to allow access. Attach bracket and assemble bypass switch.

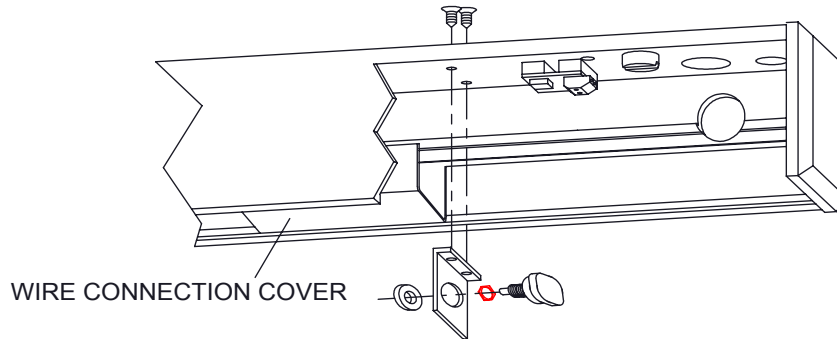

Determine power supply and unit voltage type: 24VAC/ 24VDC. CAUTION!!! DO NOT CONNECT 120VAC TO A 24 VOLT UNIT TYPE!!! Connect power supply wires, one (1) to terminal block one (1) to bypass switch. connect other bypass switch wire to terminal block . (Terminal Block can be removed for easier wiring). Slide wiring connection cover over wire connections.

CAUTION:
Improper voltage to unit, will result in damage to unit and void warranty.

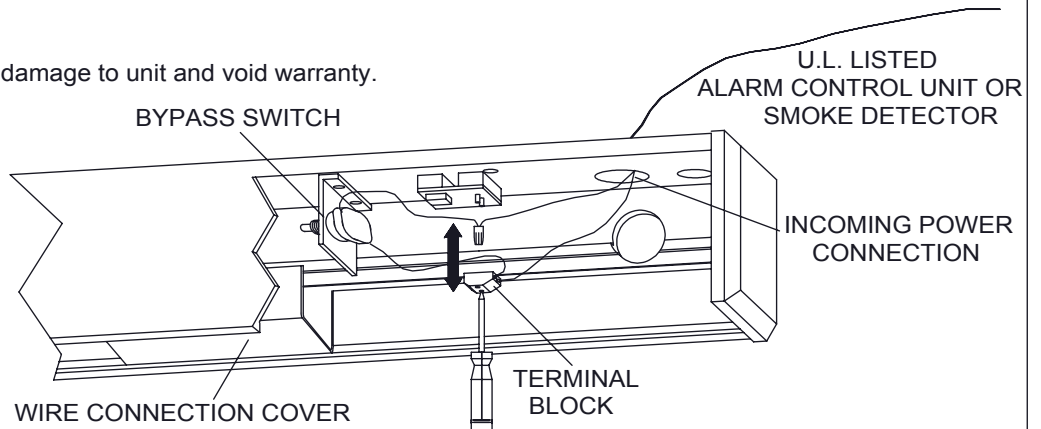

NOTE:
All wiring must comply with national, state and local electrical codes.

NOTE:
THIS CONNECTION IS NOT POLARITY DEPENDENT.
TERMINAL BLOCK 18awg MAX.